

| V-MAXX AUTOSPORT COILOVER SUSPENSION KITS | TÜV GOCA | YEAR | TYPE | -MM FRONT | -MM REAR |  | ΛΙΑΝΙΚΗ ΤΙΜΗ ΜΕ ΦΠΑ |
|--|-------------|---------|-------|--------------|-------------|---|---------------------------|
| MODEL/APPLICATION | | | | | | | |
| SKODA | | | | | | | Art.Nr. |
| Fabia 1.2/1.4/Stationw. | ✓ | 12.99- | 6Y5/J | 35 → 60 | 30 → 60 | 60 VS 12** | 540,00 |
| Fabia 2.0/1.4 TDi/1.9SDi/1.9TDi/Stationw. | ✓ | 12.99- | 6Y5/J | 35 → 60 | 30 → 60 | 60 VS 12** | 540,00 |
| Octavia 1.4/1.6/1.8 20V/1.8T/2.0/1.9SDi/1.9TDi excl. 4x4 | ✓ | 2.97-04 | 1U | 35 → 65 | 30 → 60 | 60 AV 04** | 480,00 |
| Octavia 4x4 1.8/1.8T/2.0/2.3 V5/2.8 V6/1.9TDi | ✓ | 2.97-04 | 1U | 30 → 60 | 30 → 50 | 60 AV 06 | 600,00 |
| Octavia RS/VRS 1.8T 20V | ✓ | 2.97-04 | 1U | 35 → 50 | 30 → 60 | 60 AV 07 | 540,00 |
| Octavia Stationw. 1.4/1.6/1.8 20V/1.8T/2.0/1.9SDi/1.9TDi excl. 4x4 | ✓ | 9.98-04 | 1U | 35 → 65 | 30 → 60 | 60 AV 04** | 480,00 |
| Octavia Stationw. 4x4 1.8/1.8T/2.0/2.3 V5/2.8 V6/1.9TDi | ✓ | 9.98-04 | 1U | 30 → 60 | 30 → 50 | 60 AV 06 | 600,00 |
| Octavia/Stationw. 1.4/1.6/1.8T/2.0/2.0T/DSG/1.9TDi (Ø 50mm!!) | ✓ | 04- | 1Z3 | 30 → 70 | 30 → 75 | 60 AV 16/50 | 540,00 |
| Octavia/Stationw. 1.4/1.6/1.8T/2.0/2.0T/DSG/1.9TDi (Ø 55mm!!) | ✓ | 04- | 1Z3 | 30 → 70 | 30 → 75 | 60 AV 16/55 | 540,00 |
| Octavia/Stationw. RS/VRS/1.9TDi DSG/2.0TDi/DSG (Ø 50mm!!) | ✓ | 04- | 1Z3 | 30 → 70 | 30 → 75 | 60 AV 17/50 | 540,00 |
| Octavia/Stationw. RS/VRS/1.9TDi DSG/2.0TDi/DSG (Ø 55mm!!) | ✓ | 04- | 1Z3 | 30 → 70 | 30 → 75 | 60 AV 17/55 | 540,00 |
| Superb 2.0/1.8T/2.8 V6/1.9TDi/2.5 V6 TDi excl. Aut. | ✓ | 02-08 | 3U | 30 → 65 | 30 → 60 | 60 AV 05 | 540,00 |

STABILIZER-CONNECTION BOLTS

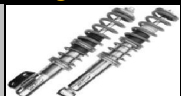
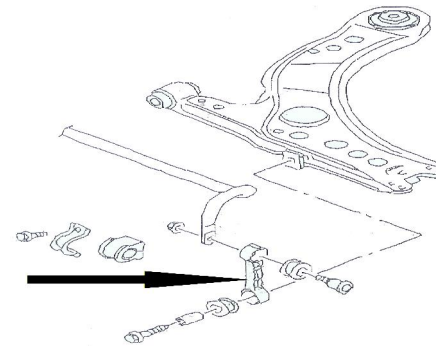

| | | | |
|--|---------|------------------------------|-------|
| Skoda Octavia 2WD | Art.Nr. | SBG4 Kit = Adjustable | 60,00 |
| Seat Ibiza 6L / Skoda Fabia / VW Polo 9N / Fox | Art.Nr. | SBMO Kit = Adjustable | 60,00 |

** = **ALWAYS** use special stabilizer connection bolts

LOWERING MORE THAN LISTED MEASUREMENTS, WILL VOID THE WARRANTY AND IS DONE AT OWN RISK!!

IN SOME CASES WHEELSPACERS MAY BE NECESSARY AND MUST BE USED

ALWAYS ALIGN THE CAR AFTER REPLACING SUSPENSION PARTS